



전자 회로 2

Lecture 6 (Differential Amp.)



공지사항 – 중간고사 일정

- 범위: ~ 배운 곳 (Differential Amp.)
- 일시: 10월 21일
- 장소:원천관508

The Differential Amplifiers

- General amp.
 - 2 inputs / 2 outputs

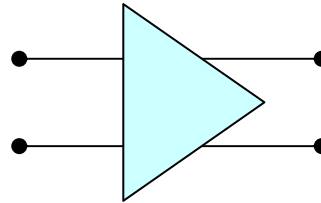

- OP-Amp.
 - 2 inputs / 1 output

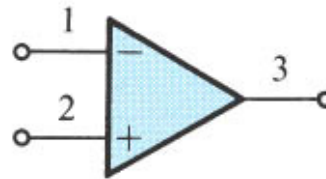

- Single stage Amp. (CS/CG/CD, CE/CB/CC)
 - 1 input / 1 output

The MOS differential pair

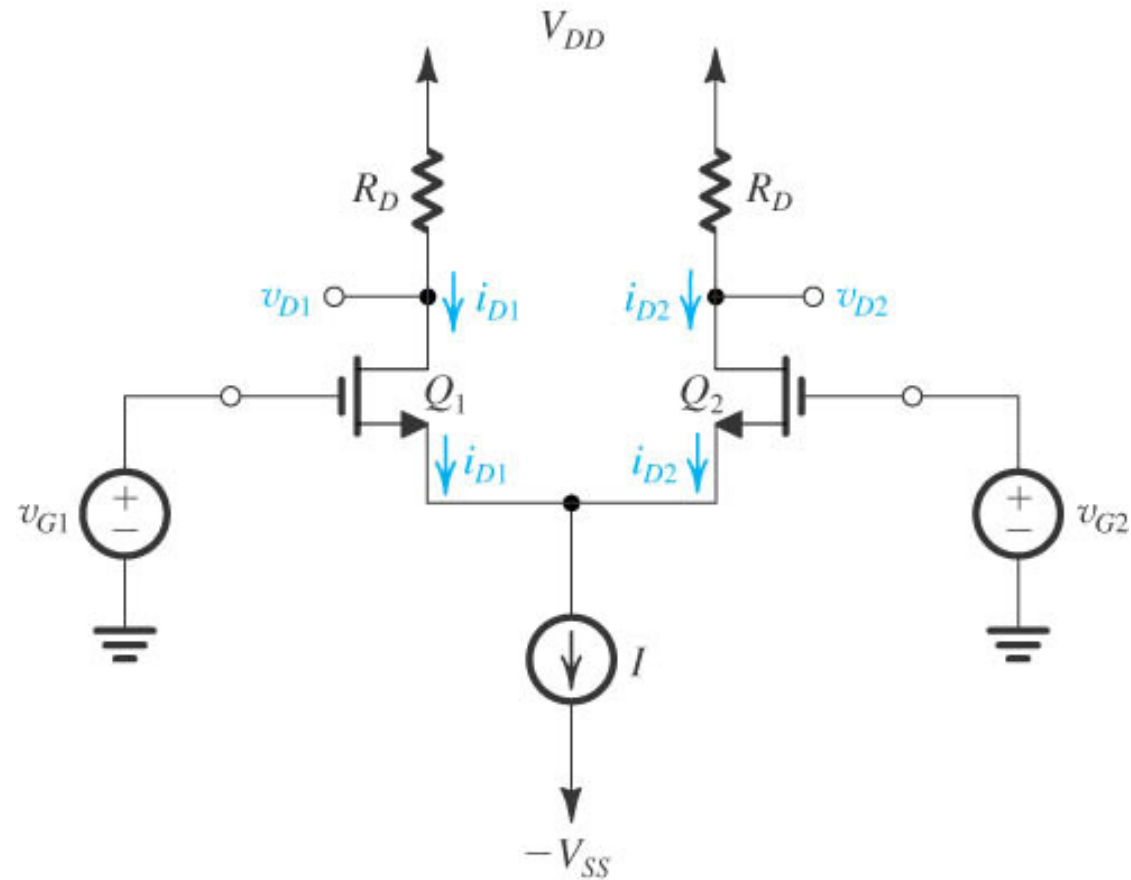

Common-Mode input voltage

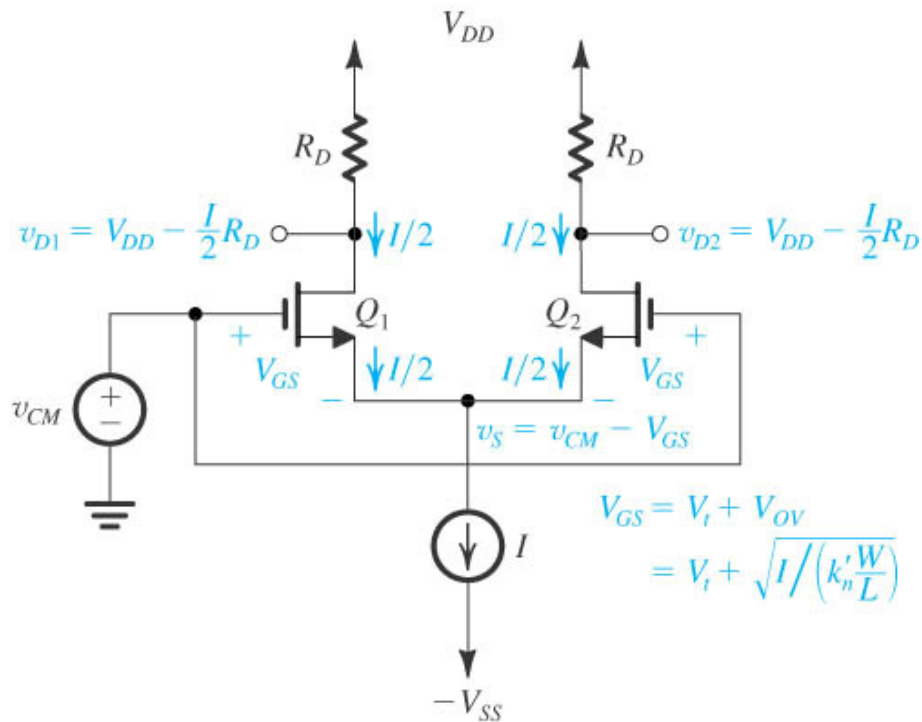

$$v_{G1} = v_{G2} = v_{CM}$$

$$i_{D1} = i_{D2} = I/2$$

$$v_S = v_{CM} - V_{GS}$$

$$\frac{I}{2} = \frac{1}{2}k_n' \frac{W}{L} (V_{GS} - V_t)^2$$

$$v_{D1} = v_{D2} = V_{DD} - \frac{I}{2}R_D$$

$$v_{G2} - v_{G1} = 0 \Rightarrow v_{D2} - v_{D1} = 0$$

Input common mode range:

$$v_{CMmax} = V_t + V_{DD} - \frac{I}{2}R_D$$

$$v_{CMmin} = -V_{SS} + V_{CS} + V_t + V_{OV}$$

Differential input voltage

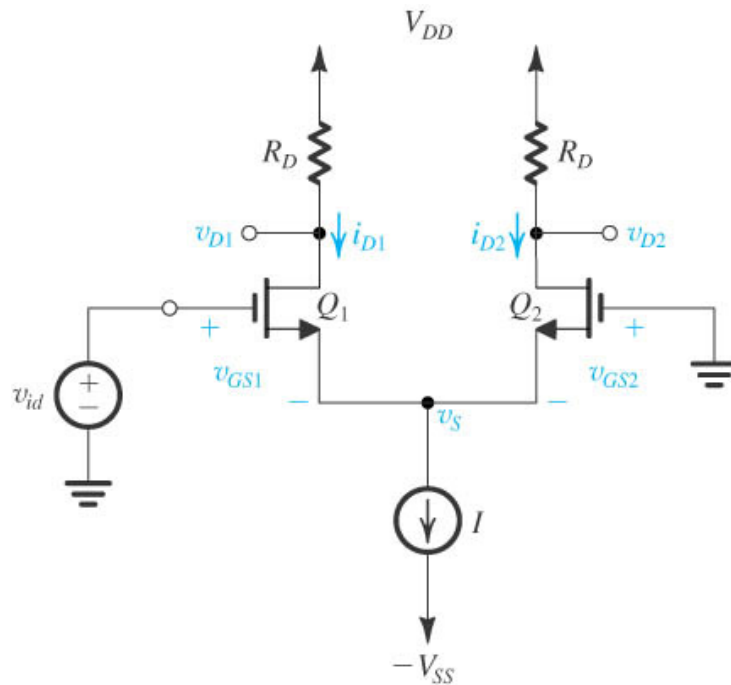

Differential input: $v_{id} = v_{G1} - v_{G2}$

Differential output: $v_{od} = v_{D1} - v_{D2}$

$$I_{D1} = I, I_{D2} = 0 \rightarrow I = \frac{1}{2} k_n' \frac{W}{L} (v_{GS1} - V_t)^2$$

$$v_{GS1} = V_t + \sqrt{2I/k_n' (W/L)}$$

$$= V_t + \sqrt{2} V_{OV}$$

$$v_{idmax} = v_{GS1} + v_S$$

$$= V_t + \sqrt{2} V_{OV} - V_t$$

$$= \sqrt{2} V_{OV}$$

V_{OV} : $I_{D1} = I/2$ 일 때의
overdrive voltage

$$v_{id} > 0 \rightarrow v_{od} < 0$$

$$v_{id} < 0 \rightarrow v_{od} > 0$$

$$-\sqrt{2} V_{OV} \leq v_{id} \leq \sqrt{2} V_{OV}$$

Large-signal operation (exact calculation)

$$i_{D1} = \frac{1}{2} k_n' \frac{W}{L} (v_{GS1} - V_t)^2$$

$$i_{D2} = \frac{1}{2} k_n' \frac{W}{L} (v_{GS2} - V_t)^2$$

$$\sqrt{i_{D1}} = \sqrt{\frac{1}{2} k_n' \frac{W}{L}} (v_{GS1} - V_t)$$

$$\sqrt{i_{D2}} = \sqrt{\frac{1}{2} k_n' \frac{W}{L}} (v_{GS2} - V_t)$$

$$v_{GS1} - v_{GS2} = v_{G1} - v_{G2} = v_{id}$$

$$\begin{aligned} \sqrt{i_{D1}} - \sqrt{i_{D2}} &= \sqrt{\frac{1}{2} k_n' \frac{W}{L}} v_{id} \\ i_{D1} + i_{D2} &= I \end{aligned}$$

$$i_{D1} + i_{D2} - 2\sqrt{i_{D1}i_{D2}} = \frac{1}{2} k_n' \frac{W}{L} v_{id}^2$$

$$i_{D1} = \frac{I}{2} \pm \sqrt{k_n' \frac{W}{L} I} \left(\frac{v_{id}}{2} \right) \sqrt{1 - \frac{(v_{id}/2)^2}{I/k_n'(W/L)}}$$

$$i_{D1} = \frac{I}{2} + \frac{I}{V_{OV}} \left(\frac{v_{id}}{2} \right) \sqrt{1 - \left(\frac{v_{id}/2}{V_{OV}} \right)^2}$$

$$i_{D2} = \frac{I}{2} - \frac{I}{V_{OV}} \left(\frac{v_{id}}{2} \right) \sqrt{1 - \left(\frac{v_{id}/2}{V_{OV}} \right)^2}$$

Linear approx.:

$$i_{D1} \cong \frac{I}{2} + \frac{I}{2V_{OV}} v_{id}$$

$$i_{D2} \cong \frac{I}{2} - \frac{I}{2V_{OV}} v_{id}$$

Normalized plot (Large signal)

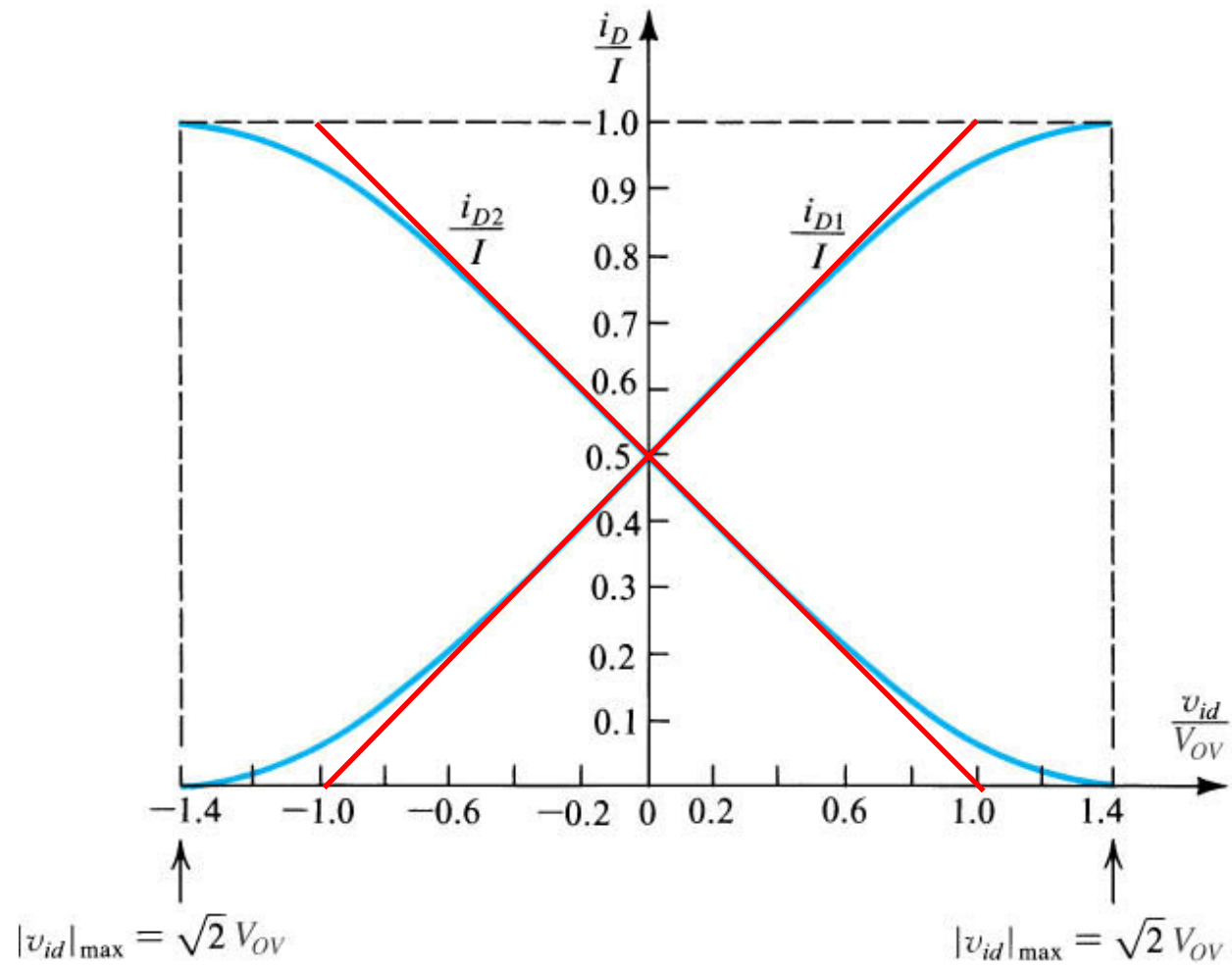

Small-signal operation

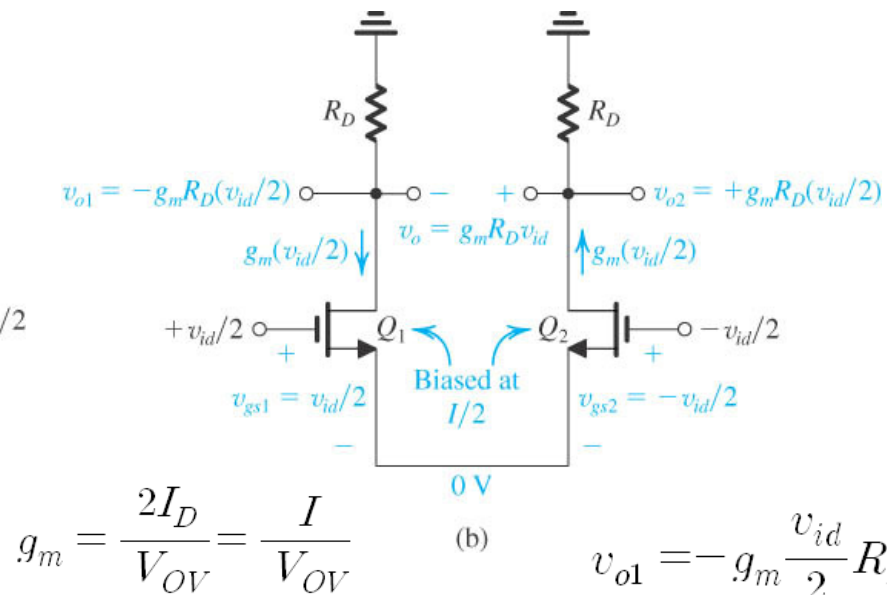
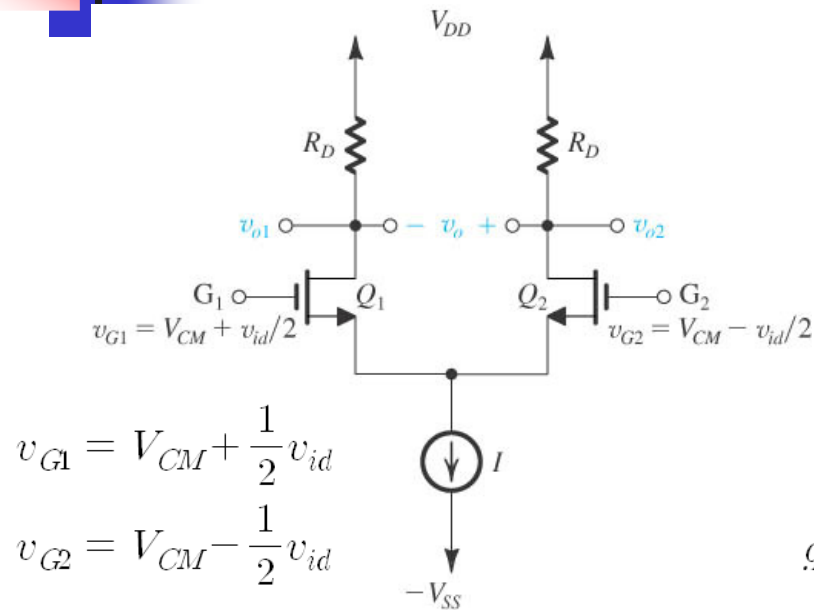

$$v_{o1} = -g_m \frac{v_{id}}{2} R_D$$

$$v_{o2} = g_m \frac{v_{id}}{2} R_D$$

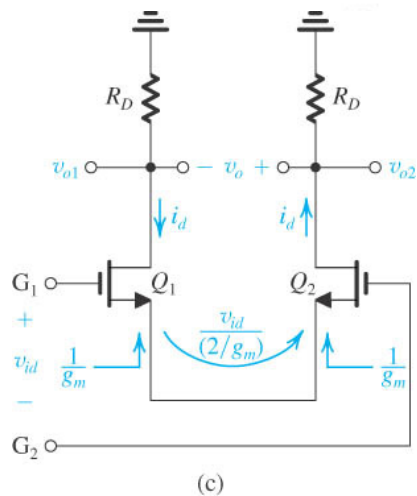

Differential gain: $A_d \equiv \frac{v_{o1} - v_{o2}}{v_{id}} = g_m R_D$

Effect of channel length modulation r_o

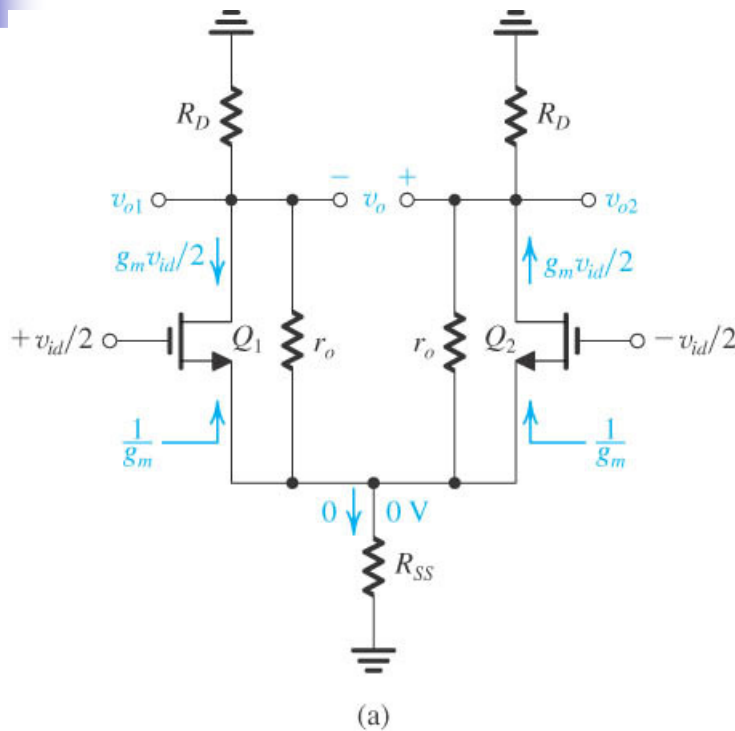

The differential half circuit

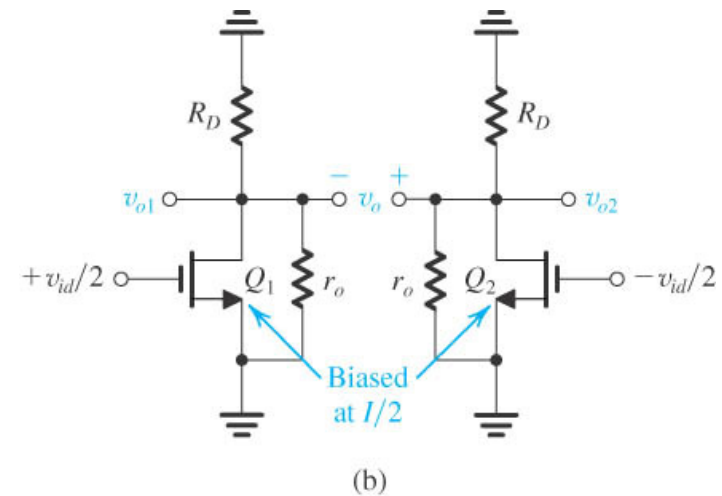

$$v_{o1} = -g_m (R_D \parallel r_o) (v_{id}/2)$$

$$v_{o2} = g_m (R_D \parallel r_o) (v_{id}/2)$$

$$v_o = v_{o1} - v_{o2} = -g_m (R_D \parallel r_o) v_{id}$$

Common-mode gain & CMRR

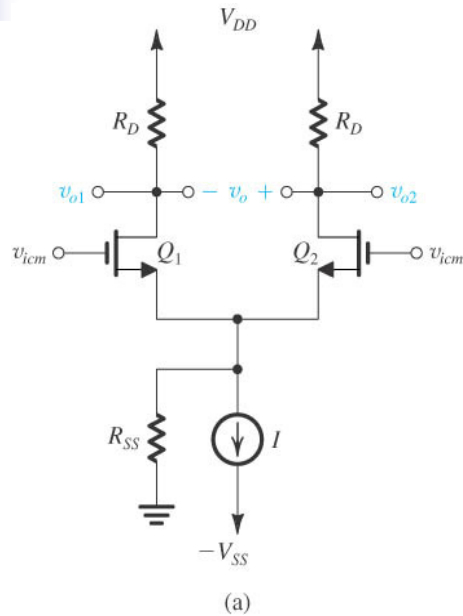

The CM half circuit

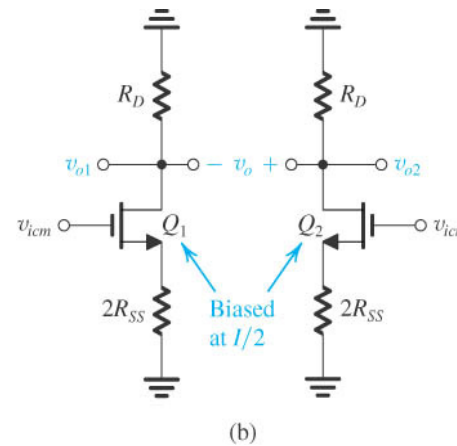

- Single ended output: $v_o = v_{o1}$ or v_{o2}

$$A_{cm} = \frac{v_{o1}}{v_{icm}} = \frac{v_{o2}}{v_{icm}} = -\frac{R_D}{1/g_m + 2R_{SS}} \cong -\frac{R_D}{2R_{SS}}$$

$$|A_{cm}| = \frac{R_D}{2R_{SS}}$$

$$|A_d| = \frac{1}{2}g_m R_D$$

$$CMRR = \left| \frac{A_d}{A_{cm}} \right| = g_m R_{SS}$$

- Differential output: $v_o = v_{o1} - v_{o2}$

$$A_{cm} = 0 \quad \because v_o = v_{o1} - v_{o2} = 0$$

$$CMRR = \left| \frac{A_d}{A_{cm}} \right| = \infty$$

Effect of R_D and g_m mismatch on CMRR

R_D mismatch

$$v_{o1} \cong -\frac{R_D}{2R_{SS}}v_{icm}$$

$$v_{o2} \cong \frac{R_D + \Delta R_D}{2R_{SS}}v_{icm}$$

$$v_o = v_{o1} - v_{o2} = \frac{\Delta R_D}{2R_{SS}}v_{icm}$$

$$A_{cm} = \frac{\Delta R_D}{2R_{SS}} = \frac{R_D}{2R_{SS}} \frac{\Delta R_D}{R_D}$$

$$A_d \cong -g_m R_D$$

$$CMRR = \left| \frac{A_d}{A_{cm}} \right| = (2g_m R_{SS}) / \left(\frac{\Delta R_D}{R_D} \right)$$

g_m mismatch

$$i_{d1} = g_{m1}v_{gs1}$$

$$i_{d2} = g_{m2}v_{gs2}$$

$$\frac{i_{d1}}{i_{d2}} = \frac{g_{m1}}{g_{m2}}$$

$$i_{d2} = \frac{g_{m2}}{g_{m1}}i_{d1}$$

$$v_S = (i_{d1} + i_{d2})R_{SS}$$

$$v_S \cong v_{icm} (\because \text{source follower})$$

$$i_{d1} + i_{d2} \cong \frac{v_{icm}}{R_{SS}}$$

$$i_{d1} = \frac{g_{m1}}{(g_{m1} + g_{m2})} \frac{v_{icm}}{R_{SS}}$$

$$i_{d2} = \frac{g_{m2}}{(g_{m1} + g_{m2})} \frac{v_{icm}}{R_{SS}}$$

$$v_{o1} - v_{o2} = -R_D(i_{d1} - i_{d2}) = -\frac{\Delta g_m R_D}{2g_m R_{SS}}v_{icm}$$

$$A_{cm} = -\left(\frac{R_D}{2R_{SS}} \right) \left(\frac{\Delta g_m}{g_m} \right)$$

$$A_d = -g_m R_D$$

$$CMRR = \left| \frac{A_d}{A_{cm}} \right| = 2g_m R_{SS} / \left(\frac{\Delta g_m}{g_m} \right)$$

